

RSCDS Paris Branch – Cheers Chambéry! – Saturday evening dance

1 THE FINDLAYS' JIG J32 · 3/4L

Roy Goldring: 14 Social Dances for 2000 · Crib: E-cribs · Diagram: Keith Rose's Diagrams

- 1– 1c lead down the middle and up, 2c+3c step in for
- 9– 1c+2c+3c Allemande (to 3,2,1)
- 17– 1c long cast to 1pl (3c+2c down) ; 2c repeat (1c+3c down) (2,1,3)
- 25– Circle6 and back

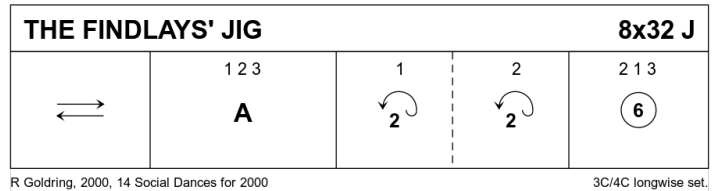

2 THE CASTLE OF MEY R32 · 3/4L

John Walton: QE Diamond Jubilee Dances · Crib: E-cribs · Diagram: Keith Rose's Diagrams

- 1– Inveran Reels3 on the sides, 1c crossing down to start (1,2,3)
- 9– 1c+2c DbIFig8, 1c cross down to start
- 17– 1c lead down the middle and up, finishing for
- 25– 1c+2c Poussette

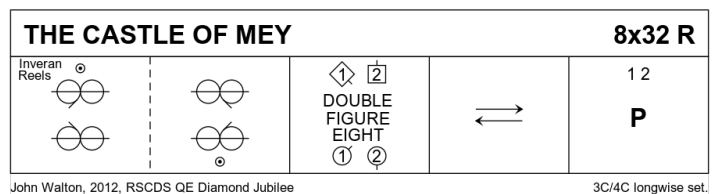

3 THE ROSE OF THE NORTH S32 · 3/4L

Roy Goldring: Silver Jubilee 25 - Leeds Branch · Crib: E-cribs · Diagram: Keith Rose's Diagrams

- 1-4 1c lead down, cross below 3c and cast up into 2plx (2c up)
- 5-16 2c+1c+3c R&L for 3 couples
- 17– 1c set to and turn corners, to finish BtoB in the centre, 1M facing up, 1W facing down
- 25– 1M+2c & 1W+3c Circle3 L (at end 1c pull Rsh back to face P) ; 1c set, petronella to 2pl

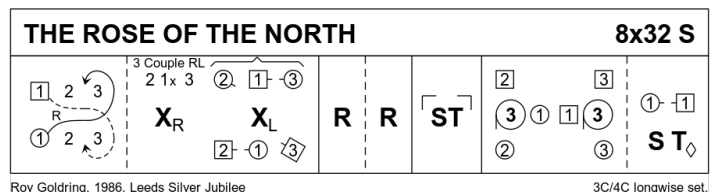

4 LINKS WITH ST PETERSBURG J32 · 3/4L

Malcolm Brown: RSCDS XLVI 10 · Crib: E-cribs · Diagram: Keith Rose's Diagrams

- 1– 1c+2c S&Link, finish 2c facing 1c NHJ ; S&Link to (2x,1x,3)
- 9– 1c, 2c following, dance down {3}, change sides with NHJ, W passing above M and under his arm, 2c+1c dance up to (2,1,3), 2c facing out
- 17– 2c turn 1c EH on sides ; 1c turn 3c EH, 1c finish BtoB facing 1cnr
- 25– SetH&G , petronella to (2,1,3)

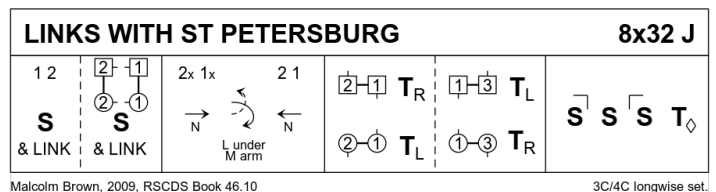

5 SCOTT MEIKLE R32 · 4/4L

Alice McLean: RSCDS XLVI 3 · Crib: E-cribs · Diagram: Keith Rose's Diagrams

- 1- 1c cross RH | cast (2c up) ; ½ Fig8 up (2,1,3,4)
- 9- 1c+3c RHA, LHA (2,1,3,4)
- 17- Lsh opposing Reels3 across: (1W+3W behind dancing as one) with 2c and (3M+1M behind) with 4c (to 2,3,1,4)
- 25- 1c+4c ½ R&L ; turn RH 1½ (2,3,4,1)

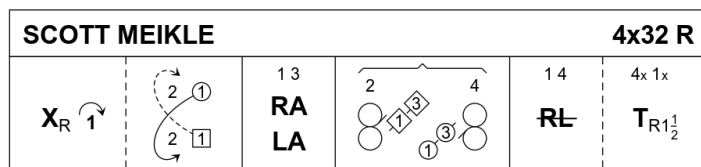

Alice McLean, Laurieston Collection 1, RSCDS Book 46.3

4C/4C longwise set.

6 BROADWAY S32 · 3/3L

Chris Ronald: The Big Apple Collection · Crib: E-cribs · Diagram: Keith Rose's Diagrams

- 1-- 1c dance down | turn BH ; dance up and cast to 2pl (2c up) (2,1,3)
- 9-- S&Link3 into lines across ; Half Diag R&L to the L (in each line only the middle and RH persons dance)
- 17-- S&Link3 to sidelines; Half Diag R&L to the L (in each line only the middle and RH persons dance) (3x,1x,2x)
- 25-- All set | All turn P ½ and twirl to sideline | All set

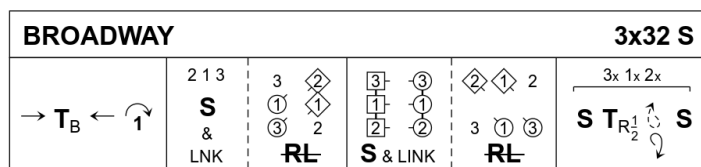

Chris Ronald, 2003, Big Apple Collection

3C/3C longwise set.

7 INCHMICKERY J32 · 5/5L

Roy Goldring: 14 Social Dances for 2000 · Crib: E-cribs · Diagram: Keith Rose's Diagrams

- 1- 1c+2c circle4 L ; 1c long cast to 3pl (2c+3c up) (2,3,1,4,5)
- 9- Teapots R ; and L (1c RHA with C on R ; LHA with C on L)
- 17- 1M+5W & 1W+2M Turn RH to places ; 1M+2W & 1W+5M repeat LH
- 25- 1c long cast to 5pl (4c+5c up) ; 5c+1c circle4 R (2,3,4,5,1)

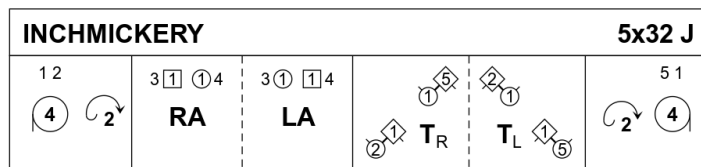

Roy Goldring, 2000, 14 Social Dances

5C/5C longwise set.

8 THE BLACKWATER REEL R32 · 3/4L

Alan Davis: RSCDS XLI 9 · Crib: E-cribs · Diagram: Keith Rose's Diagrams

- 1- 1c+2c+3c ½ RH turn | twirl R to opposite place ; chase clw half round (3,2,1)
- 9- 3c+2c ½ R&L while{4} 1c cross RH and set ; 3c+1c ½ R&L while{4} 2c cross RH and set (to 2,1,3)
- 17- Teapots R (pass Rsh) ; Teapots L, 2c+3c finish facing out
- 25- Mirror Reels3 on the sides, joining hands where possible, 1c starts in and up

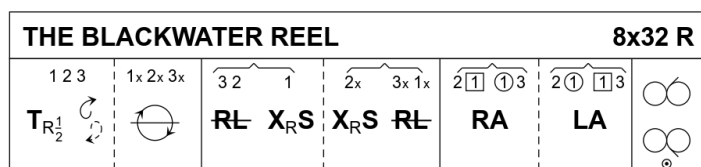

Alan Davis, 1997, RSCDS Book 41.9

3C/4C longwise set.

INTERVAL

9 THE SHETLAND SHEPHERDESS

J32 · 3/4L

Ron Wallace: *A Third Book of Graded Scottish Country Dances* · Crib: *E-cribs* · Diagram: *Keith Rose's Diagrams*

- 1-- 1c dance between 2c and cast up to place ; dance ½ Fig8 round 2c (1x,2,3)
- 9-- 1c cross down into mirror Reels3 on own side, 2c starting out and up (1,2,3)
- 17-- 1c (start inwards) change place with 2c EH and face out | 1c turn 3c EH to face up in the middle ; 1c dance to top and cast off (2,1,3)
- 25-- All A&R and clap on last beat of [28] ; All turn P RH (2,1,3)

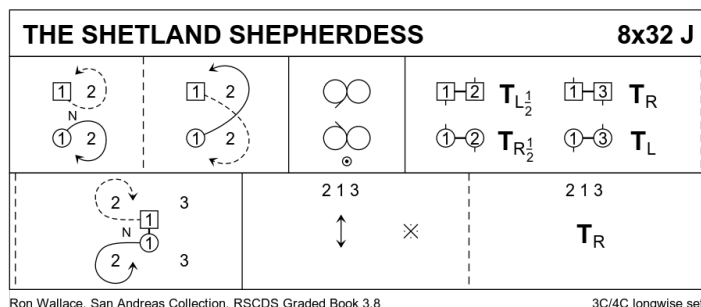

10 FIFE NESS

R32 · 3/4L

Mary Shoolbraid Brandon: *Four Scottish Country Dances 1978* · Crib: *E-cribs* · Diagram: *Keith Rose's Diagrams*

- 1-- 1c ½ RH turn to promhold, dance between 3c ; cross LH (2c up) and cast up to (2,1,3)
- 9-- 2M+1W+3M set advancing to form triangle NHJ {2}, set retiring, advancing, retiring **while**{8} 2W+1M+3W stand {2}, set advancing likewise, retiring, advancing
- 17-- 1c in promhold +2W+3W Lsh ½Reel3 in centre of set ; 1c+(2W+3M)+(3W+2M) all in promhold ½Reel3
- 25-- 1c+2M+3M ½Reel3 (finish 2x,1x,3x) ; all set and cross RH

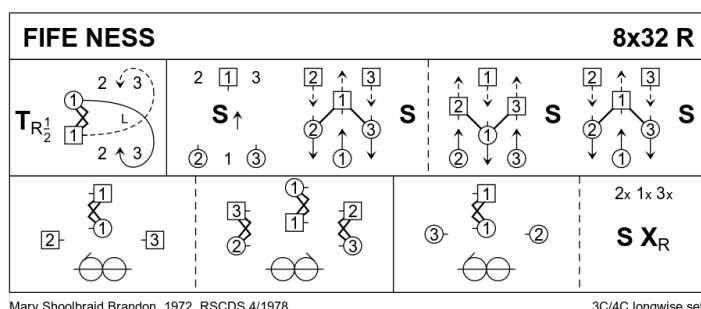

11 MY FRIEND JOE

S32 · 3/4L

Robert M Campbell: *RSCDS XXXVIII 2* · Crib: *E-cribs* · Diagram: *Keith Rose's Diagrams*

- 1-- 1M+2W set adv & turn BH ¾ and pivot R **while**{ 1W+2M chase cclw half round them, all finish on midline facing P ; 1c+2c set | turn RH ¾ into
- 9-- 2c+1c Allemande {6}, finish facing up RHJ | 1c cast and 2c lead up with loop to (2,1,3)
- 17-- All adv {1}, retire {1} | cross RH, to sidelines ; 1c+3c circle4 L (2x,1x,3x)
- 25-- All adv {1}, retire {1} | cross LH, to sidelines ; 2c+1c circle4 R

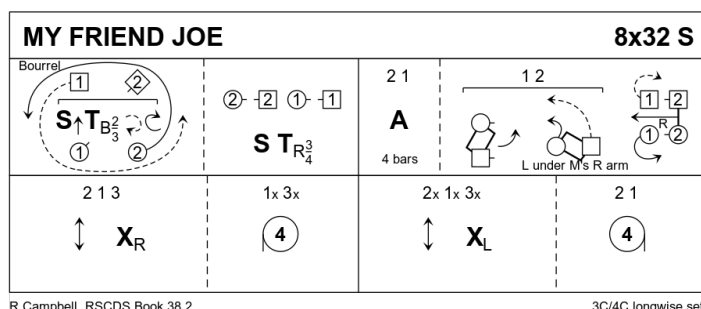

12 THE MAID OF THE MILL J40 · 3/4L

RSCDS XXI 11 · Crib: E-cribs · Diagram: Keith Rose's Diagrams

- 1- 1c turn RH | cast off 2 (2c+3c up) ; turn LH | cast back (2c+3c down)
- 9- Mirror Reels3 on opposite sides, 1c crossing down to start, 1c finish facing 1cnr and 2c in 1pl
- 17- 1c set to 1cnr | to 2cnr, finish on sides (2,1x,3) ; 1½ RH turn to 2pl (2,1,3)
- 25- 1M+3c & 1W+2c ½ Lsh Reel3 across ; 1c turn LH to 2plx
- 33- 1M+3c & 1W+2c ½ Rsh Reel3 across ; 1c turn RH to (2,1,3)

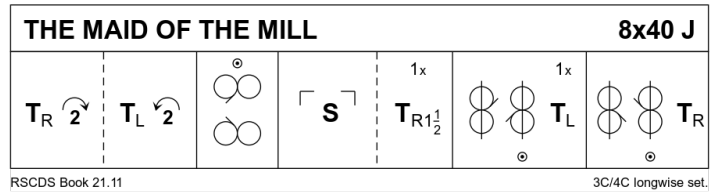

13 CRAIGLEITH R88 · 4S

Roy Goldring: A Third Book of Graded Scottish Country Dances · Crib: E-cribs · Diagram: Keith Rose's Diagrams

- 1- 1c+3c R&L
- 9- 1c+3c L-Chain
- 17- 2c+4c R&L
- 25- 2c+4c L-Chain
- 33- All W A&R, RHA, finish facing out
- 41- All W Chase clw round set (cast behind P to begin)
- 49- All M A&R, LHA, , finish facing out
- 57- All M Chase cclw round set (cast behind P to begin)
- 65- 1c+3c Promenade cclw round inside of set to own place, set facing in
- 73- 2c+4c Promenade clw round inside of set to own place, set facing in
- 81- All circle8 and back

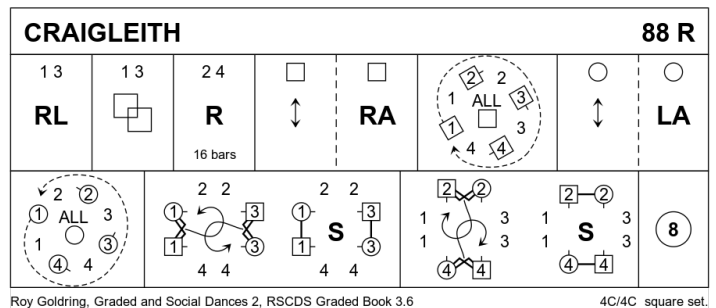

14 TRIPLE HAPPINESS S32 · 3/3L

Yoshiki Oyama: RSCDS LII 10 · Crib: E-cribs · Diagram: Keith Rose's Diagrams

- 1-- 1c A&R{1+1} taking (or shaking) RH briefly | turn LH ½ facing down ; cross LH between 2c and cast up to 1pl
- 9-- 1c+2c The Knot, 1c finish facing 1cnrs (2,1,3)
- 17-- Corners Pass and Turn BH (2,1,3)
- 25-- All chase clw ½ ; turn BH ½, face each other | cast R to exchanged places (3,1,2)

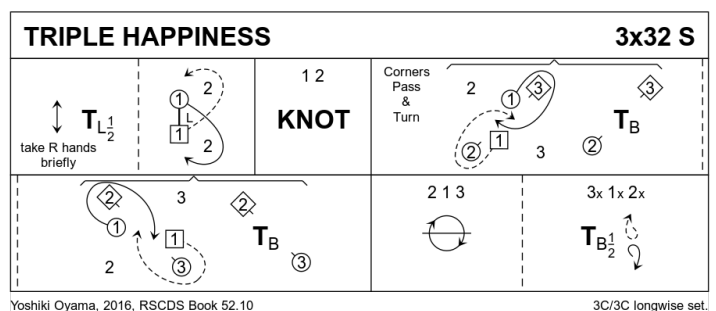

15 OLD NICK'S LUMBER ROOM

J32 · 3/4L

RSCDS XXVI 6 · Crib: E-cribs · Diagram: Keith Rose's Diagrams

- 1- 1c turn RH | cast off (2c up) ; lead between 3c and cross | cast up (to 2,1x,3)
- 9- All set | Rsh Reels3{6} across (W up, M down) (2,1x,3)
- 17- Reels3{6} on the sides, Rsh to 2cncr | 1c cross RH and face up NHJ
- 25- 2c+1c circle4 L ; 1c turn towards each other into 1c+3c circle4 R.

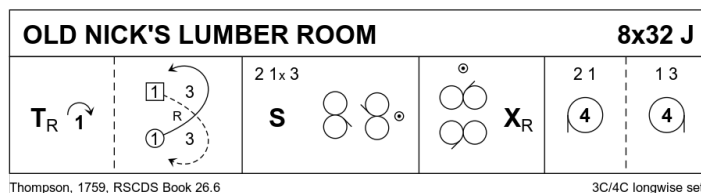

16 MRS MACPHERSON OF INVERAN

R32 · 3/4L

John Drewry: Bon Accord Book of Scottish Country Dances · Crib: E-cribs · Diagram: Keith Rose's Diagrams

- 1- 1c+2c+3c Inveran Reels3 (1c crossing top and bottom)
- 9- 1c turn RH 1½ into 2plx facing out (2c up) ; 1c cast up round 2c and cross down to (2,1,3)
- 17- G-Chain (2c cross)
- 25- circle6 and back

